

## GEARBOX 18/6

COBRANET® NETWORKED AUTOMIXER

The GearBox 18/6 CobraNet Networked Automixer is a highly integrated 18 input, 6 output digital automixer with DSP. The GearBox includes a fully managed 8-port PoE enabled Fast Ethernet switch with a Gigabit Ethernet expansion port. In addition, a WAN port is included for both third party system control and remote system access. The GearBox functionality and cost are optimized for small venues that benefit from the advantages of a networked audio system.

The GearBox accepts up to 16 networked digital inputs from any CobraNet input source (e.g. Attero Tech InBox units), and has 2 legacy mic/line analog inputs. Two legacy analog outputs complement 4 networked digital outputs, with a full 18x6 matrix mixer between inputs and outputs.

In-room remote control is provided by the RV-1 Remote Volume Control and the RC-4 Room Combining Controller. Both the RV-1 and RC-4 are single gang Decora style wall plate controls powered by the GearBox.

### FEATURES AND BENEFITS

- Fully optimized as a single box networked audio solution for small and medium venues, compatible with all Attero Tech and other CobraNet input and output devices
- 16 networked digital inputs, 2 legacy balanced mic/line analog inputs. Automixing uses Dugan-style gain sharing for seamless automixing performance
- 4 networked digital outputs, 2 legacy balanced line outputs
- +15V Phantom Power, 0dB/+25dB/+40dB mic/line gain, software controlled per analog channel
- Remote volume and room combining capability via the RV-1 Remote Volume Control and the RC-4 Room Combining Controller



- IEEE 802.3af compliant PoE will power all Attero Tech endpoint products for a true single box networked audio solution.
- DSP audio signal processing on inputs and outputs plus a full 18x6 matrix mixer.

### APPLICATIONS

- Room combining systems for hotels, conference centers, etc., up to four rooms
- Paging and background music in commercial offices, clubs, restaurants, and other retail areas
- Flexible AV systems for secondary and post-secondary educational institutions
- Houses of worship as a main mixer for primarily spoken services, or as an auxiliary to a mixing console for weddings, funerals, and other smaller gatherings

### ABOUT ATTEROTECH

Attero Tech is a leading provider of CobraNet® audio interfaces. These innovative networked audio products make it cost effective for audio installations to include CobraNet. Attero Tech is headquartered in Fort Wayne, Indiana. Contact us at:

260.496.9668

[www.atterotech.com](http://www.atterotech.com)

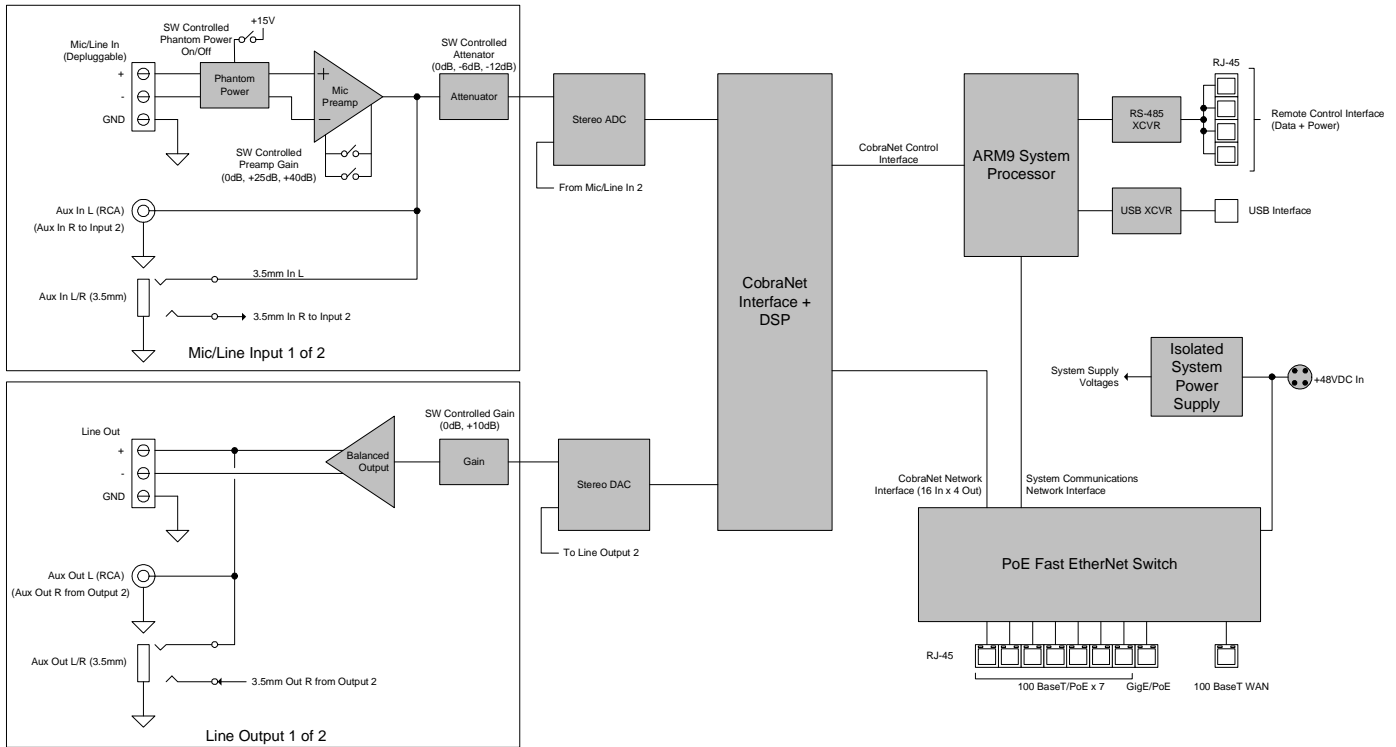

## GEARBOX HARDWARE BLOCK DIAGRAM

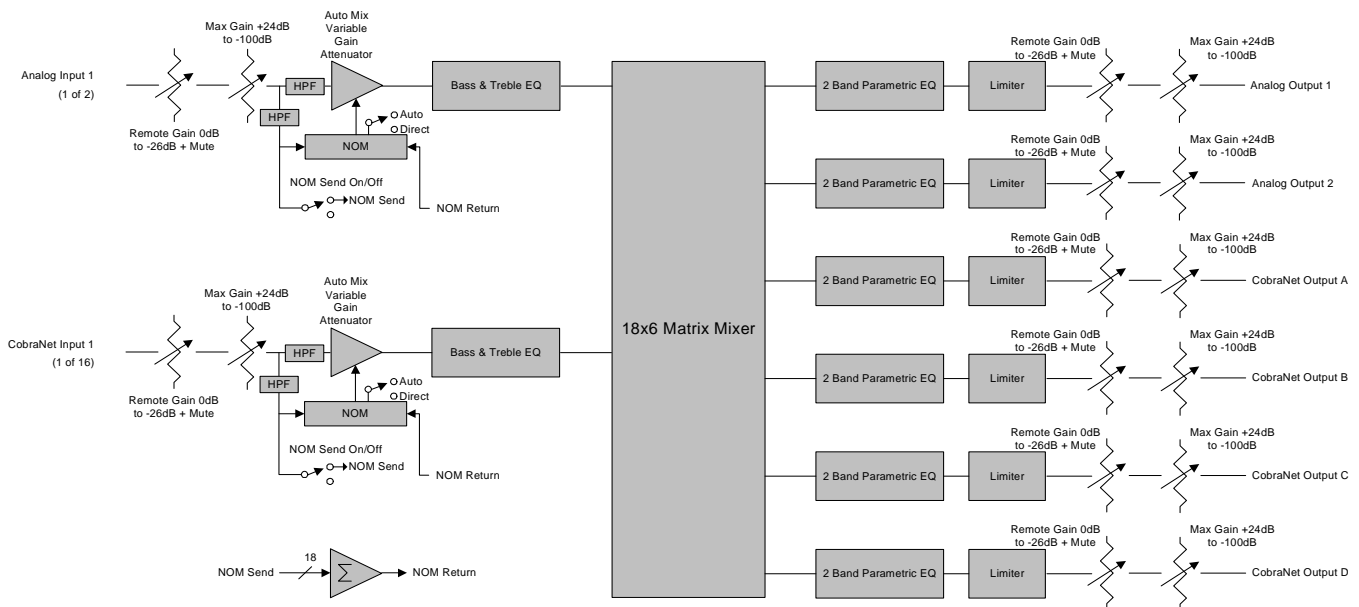

## GEARBOX DSP SIGNAL FLOW DIAGRAM

The drawings above show the hardware diagram and the DSP signal processing arrangement of the GearBox 18/6. The hardware simplicity of a networked mixer, relative to a more conventional analog mixer, is immediately evident. The lower drawing shows the audio DSP capability built into the GearBox. Auto mixing, EQ, signal limiting, remote volume and room combining control - just the ticket for small- and medium-sized venues. Add to all this an 8-Port PoE Ethernet switch, and you have the heart of a full functionality networked AV system in one rack space. What's not to like?



## GearBox 18/6 Rear Panel Connections

DC Power Input - +48VDC @ 3A, 150W maximum

Network I/O - 8-Port PoE Fast Ethernet switch. The bottom right port also supports Gig Ethernet data rates, and can be used to interconnect the GearBox with a second GearBox, or with a standard Ethernet switch for network expansion.

WAN Port - This Fast Ethernet port supports third party (eg. AMX, Crestron) system control via TCP/IP, or remote system monitoring and control. The WAN port is **not** a PoE port. CobraNet audio traffic is isolated from this port.

Atteronet Network Control Ports - These RJ-45 ports provide data and power connection to the RV-1 Remote Volume Control and the RC-4 Room Combining Controllers. Up to 16 total remote controls may be powered.

Audio In - Two separate channels of legacy analog audio input are available on the GearBox. The two balanced inputs feature switchable Phantom Power and 3 gain levels - 0dB/+25dB/+40dB. The RCA and 3.5mm stereo inputs are mixed together and with the balanced inputs (see hardware block diagram above). Software configurable attenuation can be selected before analog-to-digital conversion to optimize headroom and dynamic range.

Audio Out - Two separate channels of legacy analog audio output are available on the GearBox. The RCA and 3.5mm stereo outputs are driven by the non-inverting terminal of the balanced output. Software configurable output gain is available to optimally match the requirements of downstream audio equipment.

## SPECIFICATIONS

Mic/Line Input Type: Balanced and RF Filtered 3-pin depluggable

Phantom Power: +15 V, software controlled per channel

Input Impedance: > 1.0K ohms at any gain setting

Balanced Mic/Line Gain: 0dB, +25dB, +40dB

EIN (Mic mode): -110dBu (+40dB gain)

Maximum Analog Input Levels: +12dBu @ 0dB gain, -18dBu @ +25dB gain, -33dBu @ +40dB gain (-12dB input attenuation)

Output Type: Balanced with automatic muting upon loss of CobraNet signal

Output Impedance: 200 ohms

Output Noise: <-85dBu @ 0dB gain

Maximum Output Level: +20dBu (+10dB output gain)

System THD: <0.05% at any gain, input signal 3dB below maximum

Power Consumption: 150 W maximum at +48VDC

Dimensions: 1.75" H x 19" W x 6" D

## ARCHITECTS & ENGINEERS SPECS

The CobraNet automatic networked mixer unit shall provide 18 inputs channels (16 from the network, and two legacy analog). The unit shall provide 6 output channels (4 to the network and 2 legacy analog). A gain-sharing automixing function shall be provided for each input channel, which may be bypassed on a per channel basis. Balanced analog inputs shall provide software selectable Phantom Power and input gain. RCA and 3.5mm unbalanced stereo inputs shall also be provided. Balanced analog outputs, as well as unbalanced RCA and 3.5mm outputs shall be provided.

An 8-Port PoE Fast Ethernet switch shall be included, and one port will also support Gigabit Ethernet for expansion purposes. A WAN port will be provided for external control and monitoring.

4 RJ-45 connectors will be provided to interface any Atteronet remote control. The interface shall provide both data and power to up to 16 Atteronet remote controls.

DSP signal processing shall be provided to implement gain-sharing automatic mixing, input and output gain and equalization, matrix mixing, and room combining up to four rooms. The unit shall use a worldwide power supply, and be compliant with FCC Part 15 and CE requirements.

The unit shall be the Atterotech GearBox 18/6